

## TECHNISCHE DATEN • technical data • dati tecnici • caractéristiques techniques

<b>Breite (Einbaumaß Korpus)</b> width (fitting measure body) • larghezza • largeur (dimension du corps de l'appareil)	<b>450 mm</b>
<b>Türrahmenhöhe</b> height doorframe • altezza antina • hauteur du cadre de porte	<b>510 / 570 mm</b>
<b>Türformen</b> door • versione antina • forme de la porte	<b>rund • round • tonda • cintré</b>
<b>Breite</b> width • larghezza • largeur	<b>483 mm</b>
<b>Tiefe</b> depth • profondità • profondeur	<b>541 mm</b>
<b>Höhe</b> height • altezza • hauteur	<b>1245-1445 / 1305-1505 mm</b>
<b>Gewicht</b> weight • peso • poids	<b>106 / 110 kg</b>
<b>Nennwärmeleistung lt. EN 13229</b> nominal heat output according to EN • resa nominale secondo norme EN • puissance de chauffage selon EN	<b>6 kW</b>
<b>min. / max. Heizleistung</b> min. / max. heat output • potenzialità termica effettiva • puissance de chauffage	<b>3,5-8 kW</b>
<b>Energieeffizienzklasse</b> Energy efficiency class • classe di efficienza energetica • Classe d'efficacité énergétique	<b>A +</b>
<b>Rauchrohrabgang</b> flue pipe outlet • diametro uscita fumi • sortie de tuyau de fumées	<b>Ø 160 mm</b>
<b>Abgasmassenstrom</b> flue gas mass flow • flusso fumi • flux massique de gaz d'échappement	<b>5,14 / 5,2 g/s</b>
<b>Abgastemperatur</b> flue gas temperature • temperatura fumi • température de gaz d'échappement	<b>354 / 371 °C</b>
<b>Mindestförderdruck</b> minimum feed pressure • depressione min. necessaria • pression de transport minimum	<b>12 Pa</b>
<b>Umluftquerschnitt ohne / mit metallischer Nachheizfläche</b> convection air cross section without/with metallic heat exchanger • sezione trasversale aria convettiva senza/con scambiatore di calore metallico • section arrivée d'air sans / avec surface de chauffe métallique	<b>700 / 1000 cm<sup>2</sup></b>
<b>Dämmschichtdicken Promasil 950 KS (Boden / Seite / hinten / Decke*)</b> insulation thickness Promasil 950 KS (floor / sides / rear / ceiling*) • spessore isolante Promasil 950 KS - silicato di calcio (inferiore / laterale / posteriore / superiore*) • épaisseurs d'isolant Promasil 950 KS (sol / côté / arrière / en haut*)	<b>60 / 90 / 90 mm</b>
<b>Geschlossene Anlage möglich</b> closed construction possible • installazione ermetica possibile • installation hermétique possible	<b>ja • yes • sì • oui</b>
<b>Keramische Züge: Länge maximal</b> connection to ceramic flue heat exchangers: length max. • convogliamento in scambiatore ceramico: lungo massimo / refrattario • circulation d'air chaud dans canalisation céramique: longueur max.	<b>3 m</b>
<b>Klapptüre</b> hinged door • apertura a battente • porte ouverture latérale Anschlag von links auf rechts wechselbar • door rabbet can be exchanged from left to right • huisserie de la porte peut être mise de gauche à droite	<b>✓</b>
<b>Doppelscheibe</b> double glass • doppio vetro • double vitrage	<b>✗</b>

45x51K rund - Art. no. 360003

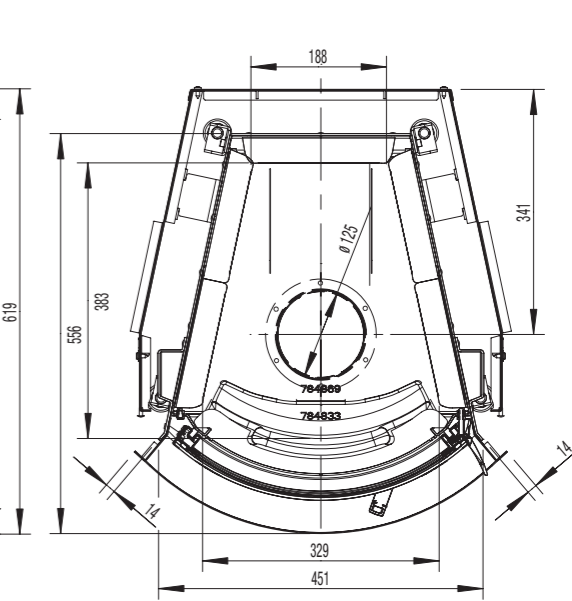
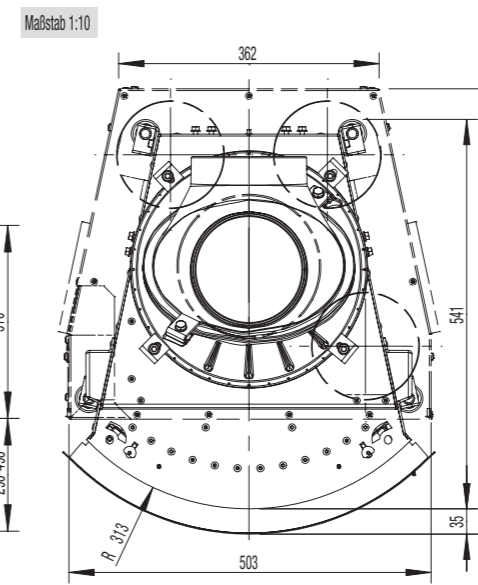
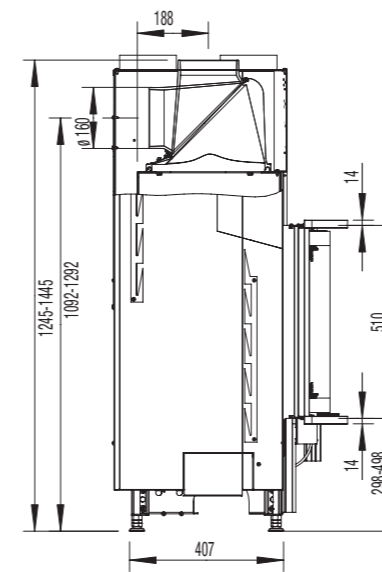
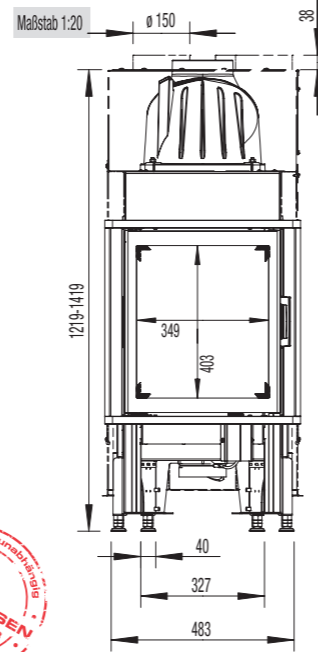

45x57K rund - Art. no. 360004

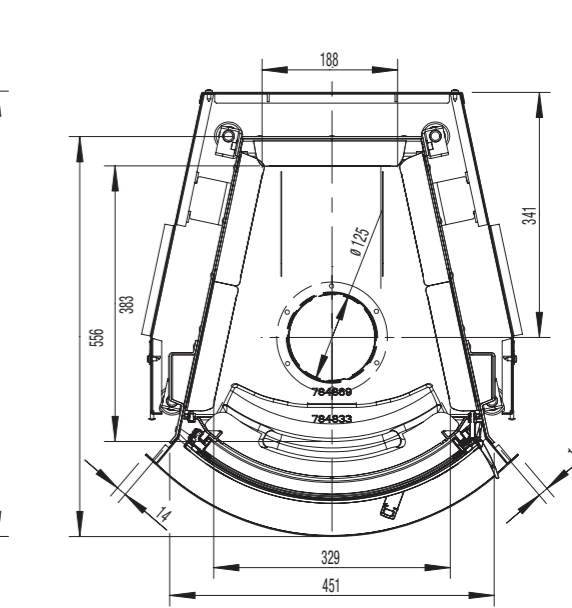
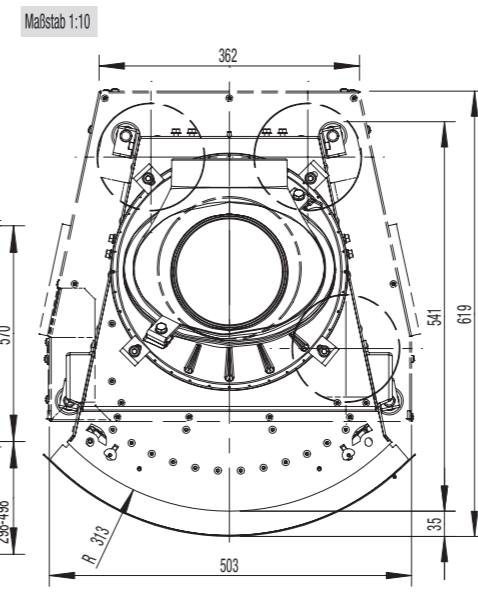
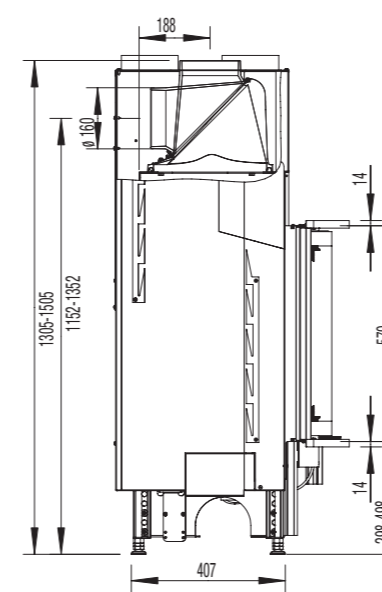
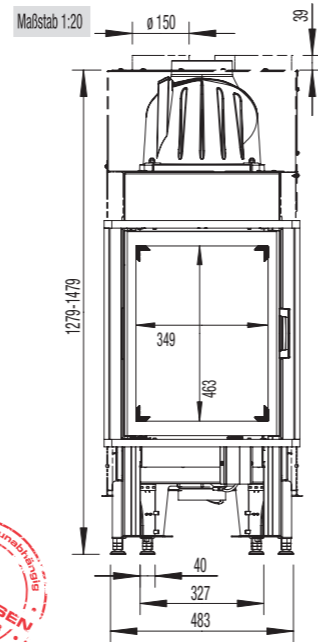

510 rund  
round / tonda / cintré

570 rund  
round / tonda / cintré

Stand: 08/2018